

Wey Knife Gate Valve MGC PN 10

2.5.30

DN 50–600
Standard construction

Materials acc. to data sheet 2.0.13

Coating acc. to data sheet 2.0.12

Flange drilling: PN 10/16 EN 1092 / ISO 7005

Face-to-face: EN 558-1 / ISO 5752 part 20

Nominal pressure PN: 10 bar

Operating pressure: Refer to table column OP

Test acc. EN 12266-1, rate A

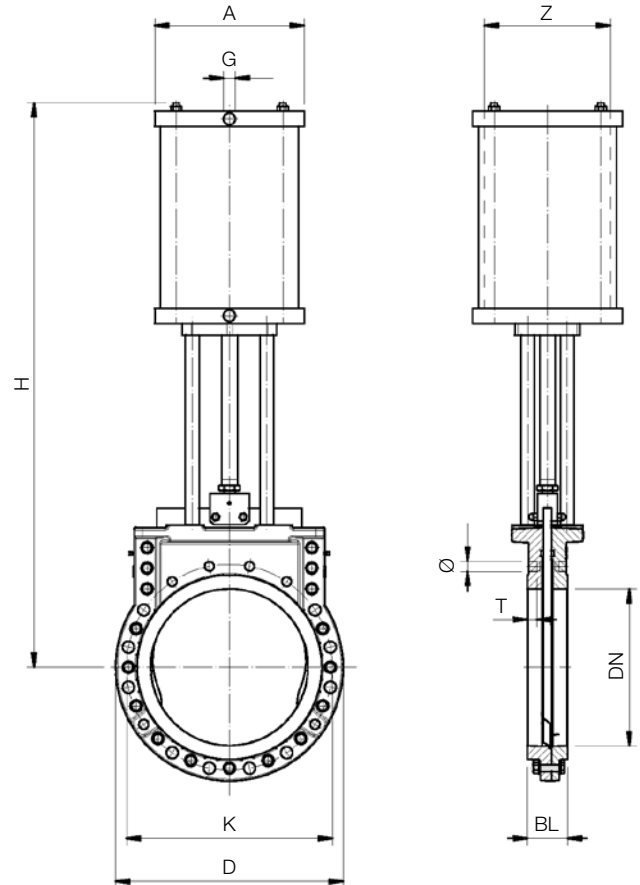

DN	D PN 10	K PN 10 ¹⁾	BL	H	Z ²⁾	A	G	Ø	T	Qty bolts	⊕	⊕	OP (bar) ²⁾	Weight [kg]
50	165	125	43	402	100	140	ISO 228-G¼	M16	17	4	4	–	10	12
65	185	145	46	453	100	140	ISO 228-G¼	M16	12	8	4	4	10	13
80	200	160	46	495	100	140	ISO 228-G¼	M16	14	8	4	4	10	14
⁴⁾ 100	220	180	52	595	160	180	ISO 228-G¼	M16	14	8	4	4	10	23
⁴⁾ 125	250	210	56	654	160	180	ISO 228-G¼	M16	16	8	4	4	10	28
150	285	240	56	728	160	180	ISO 228-G¼	M20	16	8	4	4	10	35
³⁾ 200	340	295	60	887	200	220	ISO 228-G¼	M20	15	8	2	6	10	49
250	405	350	68	1085	250	270	ISO 228-G½	M20	17	12	6	6	10	84
300	460	400	78	1291	300	320	ISO 228-G½	M20	21	12	6	6	10	123
350	520	460	78	1425	300	320	ISO 228-G½	M20	16	16	6	10	10	156
400	580	515	102	1541	350	380	ISO 228-G½	M24	24	16	6	10	10	318
450	640	565	114	1701	400	432	ISO 228-G¾	M24	29	20	10	10	10	480
500	715	620	127	1815	450	483	ISO 228-G¾	M24	28	20	10	10	10	593
600	840	725	154	2150	500	534	ISO 228-G¾	M27	33	20	10	10	10	890

¹⁾ Flange drilling PN 16 possible

²⁾ Valid at a minimum control pressure 6 bar (unproblematic media)

Other cylinder sizes according to operating and control pressure are available

³⁾ DN 50–200 in material EN-GJS-400-15 (EN-JS1030) according type MF

⁴⁾ DN 100/125 Cylinder 45° turned