

Wey Knife Gate Valve MGH PN 10

2.5.50

DN 50–600
Standard construction

Materials acc. to data sheet 2.0.13

Coating acc. to data sheet 2.0.12

Flange drilling: PN 10/16 EN 1092 / ISO 7005

Face-to-face: EN 558-1 / ISO 5752 part 20

Nominal pressure PN: 10 bar

Operating pressure: Refer to table column OP

Test acc. EN 12266-1, rate A

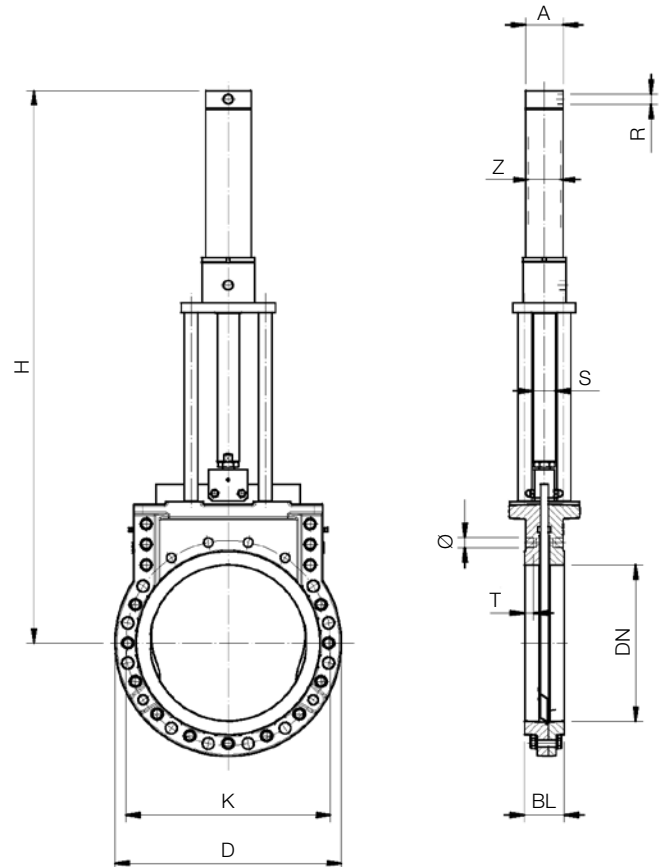

DN	D PN 10	K PN 10 ¹⁾	BL	H	Z ²⁾	S	R	A	Ø	T	Qty bolts	⊕	⊕	OP (bar) ²⁾	Weight [kg]
50	165	125	43	416	32	18	3/8	40	M16	17	4	4	–	10	12
65	185	145	46	467	32	18	3/8	40	M16	12	8	4	4	10	13
80	200	160	46	509	32	18	3/8	40	M16	14	8	4	4	10	13
100	220	180	52	581	40	22	3/8	50	M16	14	8	4	4	10	19
125	250	210	56	640	40	22	3/8	50	M16	16	8	4	4	10	25
150	285	240	56	736	50	28	3/8	60	M20	16	8	4	4	10	33
200	340	295	60	871	50	28	3/8	60	M20	15	8	2	6	10	42
250	405	350	68	1057	63	36	1/2	75	M20	17	12	6	6	10	69
300	460	400	78	1289	80	45	3/4	95	M20	21	12	6	6	10	104
350	520	460	78	1423	80	45	3/4	95	M20	16	16	6	10	10	129
400	580	515	102	1567	100	56	3/4	115	M24	24	16	6	10	10	182
450	640	565	114	1734	125	70	3/4	140	M24	29	20	10	10	10	315
500	715	620	127	1845	125	70	3/4	140	M24	28	20	10	10	10	360
600	840	725	154	2228	160	90	1 1/4	190	M27	33	20	10	10	10	610

¹⁾ Flange drilling PN 16 possible

²⁾ Valid at a minimum control pressure 100 bar for medium group 1, max. control pressure 180 bar
Other cylinder sizes according to operating and control pressure are available

³⁾ DN 50–200 in material EN-GJS-400-15 (EN-JS1030) according type MF